

## VPS-V 1.8 Gyro - Automatic Satellite Transmission System For C, X, Ku and K-Band.

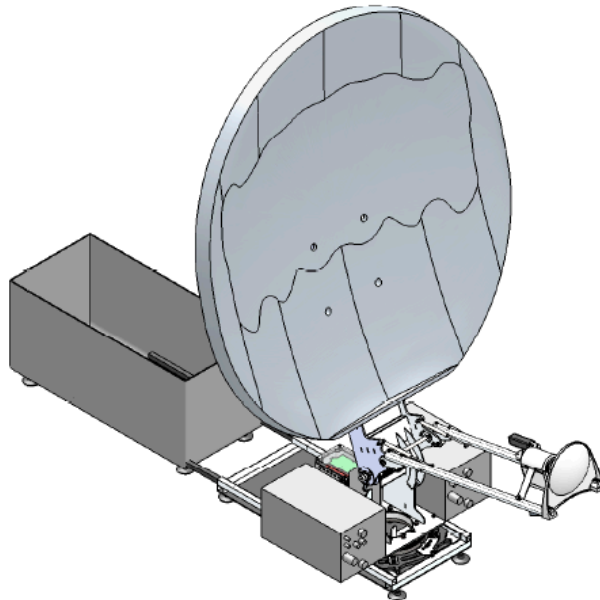

The Virtual Private Satellite™ (VPS™) antenna system is the only vehicle mounted SNG system available today that will automatically acquire the satellite, and optimize pointing as well as polarization with higher precision than can be achieved manually. It is because of this that it cannot only be used for automatic pointing but also for automatic line-up together with other features that IGP has developed. The VPS-V 1.8 Meter Fly-away is the first system incorporating a highly accurate Gyro GPS system and stepper motors, resulting in far greater accuracy.



The MSC-05 system controller is equipped with everything inside to accurately set up the system and control the stepper motor drivers.

### Main Features

- Acquires position of earth station by means of GPS, precise angle measurement devices, This technology provides absolute proof of acquisition of the right satellite,
- Fully automatic polarization setting, satellite nominal offsets variations stored in system
- Step tracking inclined orbit satellites using TLE
- Fully automatic frequency assignment and destination selection when used on VPS™ Satellite Access.
- RF package options ranging from 49 to 70 dBW EIRP with redundancy.
- 64 kbps to 60 Mbps DVB and IP options for Data and SD/HD video transmission available.
- Meets or exceeds applicable standards such as Intelsat IESS-601 and EUTELSAT EESS-502

## Specifications VPS-V-1.8M Gyro

Frequency range TX:	C-Band feed system: 5,85 - 6,5 Ghz X-Band feed system: 7,9 - 8,4 GHz Ku-Band feed systems: 13,75 – 14,5 GHz, Option: 13-13,25 GHz K-Band feed system: 17,3 - 18,4 GHz Ka-Band feed system: 27,5 - 30 GHz
Frequency range RX	C-Band feed system: 3,625 - 4,2 Ghz X-Band feed system: 7,25 - 7,75 GHz Ku-Band feed systems: 10,7 – 12,75 GHz K-Band feed system: 10,7 – 12,75 GHz, Ka-Band feed system: 20,2 - 21,2 GHz
Downconversion:	PLL Multi-band LNB, accuracy +/- 10 kHz
Effective Aperture:	190 x 180 cm
Receive Gain, Midband:	C: 40,2 dBi X: 42,4 dBi Ku: 45.4 dBi Ka: 48,9 dBi
Transmit Gain at Flange, Midband:	C: 40,2 dBi X: 42,4 dBi Ku: 47.0 dBi K: 49. dBi Ka: 53,1 dBi
Output Power:	48 – 79 dBW, according to configuration
Cross-polar suppression, -1dB Contour:	> 35 dB
VSWR:	1,2
Half Power Beamwidth	1,2°
Antenna Noise Temperature	35° K at 20° Elevation
Positioning:	Automatic
Included accessories	GPS Gyro System, controller 10 meter cable kit One Panic Buttons
User Interface:	MSC-05 keypad or Browser interface of MSC-05
Manual control in case of power failure:	By hand, after disabling brakes
Power requirement:	110 – 240 Volts – 3A through indoor unit
Indoor System weight and dimensions:	3,5 Kgs 1 U 19" Rackmount 40 cm deep

## Specifications VPS-V-1.8M Gyro (continued)

Outdoor System weight:

Rotation Base with Carbon Fiber Case doubling as ballast container: 100 x 50 x 50 cm, 62 KG

Antenna Panel Container for five-segment version: 100 x 80 x 80 cm, 30 KG

Feed System container: 150 x 30 x 30 cm, 30 KG

Custom case configurations are optional

Outdoor environment:

100% moist, must operate in rain, snow, dust and salt air  
-40 to + 55° Celsius

Indoor environment:

Humidity 5 to 95%, non-condensing, Temperature  
-10 - + 45° C.

Windloading:

Operational: 80 KMH, Survival: 120 KMH, with ballast

