



A TriPoint Global Company

**4096-433
February 4, 1997**

**Revision B
Assembly Manual**

SMALL APERTURE KU-BAND RX/O ANTENNA SYSTEM

**PRODELIN CORPORATION
1700 NE CABLE DRIVE
CONOVER, NC 28613-0368**

Small Aperture Ku-Band Rx/O Antenna System

B	Rev parts list table. Add .60M. Revise dwg of feed to show feed rods connecting to mtg bracket on outside	2/4/97	PGW
A.	Revise Parts list table cling feed rods for .76M. Add 0176-238 0176 243 .90M, 1.0M Btm Feed Rods	11/25/96	PGW
-	Original Release	04/27/95	R. Frye
REV.	DESCRIPTION	DATE	APPROVED

Table of Contents

Section I Introduction	4
<i>1.0 General Information</i>	<i>4</i>
<i>1.1 Unpacking and Inspection</i>	<i>4</i>
<i>1.2 Freight Damage</i>	<i>4</i>
<i>1.3 Material - Missing or Damaged</i>	<i>4</i>
<i>1.4 Mechanical Installation Tools</i>	<i>5</i>
<i>1.5 Torque Values</i>	<i>5</i>
<i>1.6 Foundation Requirements</i>	<i>6</i>
Section II Antenna Assembly	7
<i>2.0 Antenna Assembly Overview</i>	<i>7</i>
<i>2.1 Mount and Reflector Assembly</i>	<i>7</i>
<i>2.2 Feed Assembly</i>	<i>9</i>
<i>2.3 Feed Assembly Parts List Table</i>	<i>10</i>
Section III Satellite Alignment	13
<i>3.0 Satellite Alignment</i>	<i>13</i>
Section IV Maintenance	15
<i>4.0 Maintenance Overview</i>	<i>15</i>
<i>4.1 Periodic Inspection</i>	<i>15</i>

Section I Introduction

1.0 General Information

This manual describes the assembly and installation of Prodelin's small aperture mount. The Prodelin small aperture system is a rugged and reliable antenna system which will operate in the Ku-band receive frequency band with high efficiency and at the same time successfully withstand the effects of the environment.

These instructions are listed by sections that cover all areas of assembly and installation. Additional sections are included in the manual to provide information on antenna alignment to satellite and maintenance.

1.1 Unpacking and Inspection

The antenna containers should be unpacked and inspected at the earliest date to insure that all material has been received and is in good condition. A complete packing list for each major component is supplied.

1.2 Freight Damage

Any damage to materials while in transit should be immediately directed to the freight carrier. He will instruct you on matters regarding any freight damage claims.

1.3 Material - Missing or Damaged

Any questions regarding missing or damaged materials that is not due to the freight carrier should be directed to Prodelin's Customer Service Department at:

**PRODELIN CORPORATION
1700 NE CABLE DRIVE
PO BOX 368
CONOVER, NORTH CAROLINA 28613
(828) 464-4141**

1.4 Mechanical Installation Tools

The following tools are suggested for the antenna installation

1 Ratchet - 3/8" drive	1 Torque wrench
1 Socket 7/16" - 3/8" drive	1 Compass
1 socket 1/2" - 3/8" drive	1 Inclinator
1 Wrench combination - 7/1 6"	1 Magnetic level
1 Wrench Combination - 1/2"	

1.5 Torque Values

The following torque values should be used during assembly.

Hardware Size	Torque
1/4" Feed System Hardware	5 ft/lb.
5/16" Az/El Cap Hardware	11 ft/lb.
Back Reflector Screws	10 ft/lb.

Note: If reflector screws must be removed after initial install, it is important that they be reinstalled in the original thread paths in the reflector.

1.6 Foundation Requirements

All local building codes should be adhered to, i.e. grounding, foundation requirements, zoning rules, setbacks, etc. The following figure shows a suggested in-ground mast foundation.

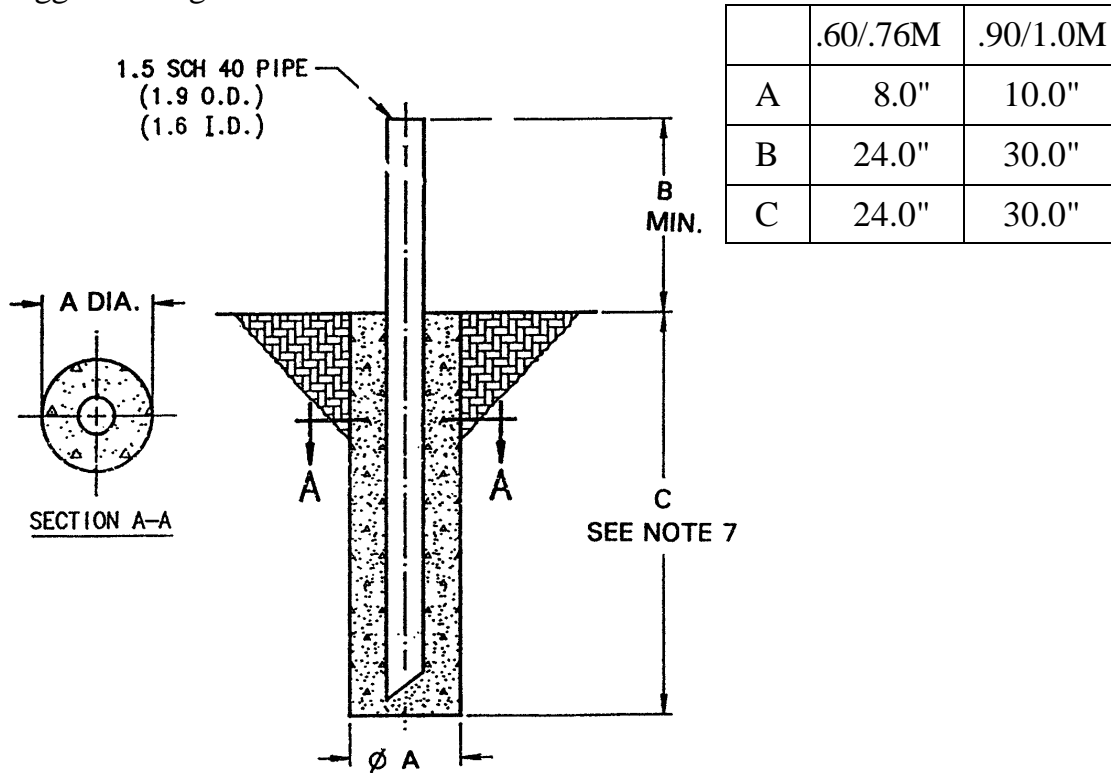

NOTES:

1. 1.5" schedule 40 pipe should conform with ASTM A36 structural steel.
2. All concrete should conform to building code standards and have a minimum compressive strength of 3000PSI at 28 days (per ACI-318-77).
3. Soil bearing capacity should be no less than 2000 PSF.
4. Concrete should be poured against undisturbed soil.
5. Allow concrete 24 hour set time before installation of antenna.
6. The antenna should be properly grounded to meet applicable local codes.
7. Minimum depth as shown or extended to local frost line.

(Prodelin Corporation does not represent or warrant that any particular design or size of foundation is appropriate for any locality or earth station installation.)

Section II Antenna Assembly

2.0 Antenna Assembly Overview

The small aperture mount is designed to support Prodelin's .60M, .76M, .90M or 1.0M, Ku-band receive only, antenna systems. Refer to the figures and parts list and follow the instructions in the listed sequence.

2.1 Mount and Reflector Assembly

Step 1: Attach the reflector (item# 3) to the Az/EI Cap (item #1) with [4] hi-lo screws (item#2). *Note: The bottom of the reflector has a hole for the feed rod, the top does not.* Tighten the [4] screws to 10 ft/lb. See figure 2.1-1.

Step 2: Place the Az/EI Cap/reflector assembly over the mast pipe and secure by tightening the two 5/16" nuts on the canister, snug, but not tight enough to prevent Azimuth rotation.

Reflector And Mount Parts List			
ITEM #	PART #	DESCRIPTION	QTY
1	0181-574	Az/EI Ca Assembly	1
2	8319-045	Screws, Hi-Lo Thd. 11/32-14 X 1-1/8"	4
3	Varies	.60M Reflector	1
		.76M Reflector	1
		.90M Reflector	1
		1.0M Reflector	1

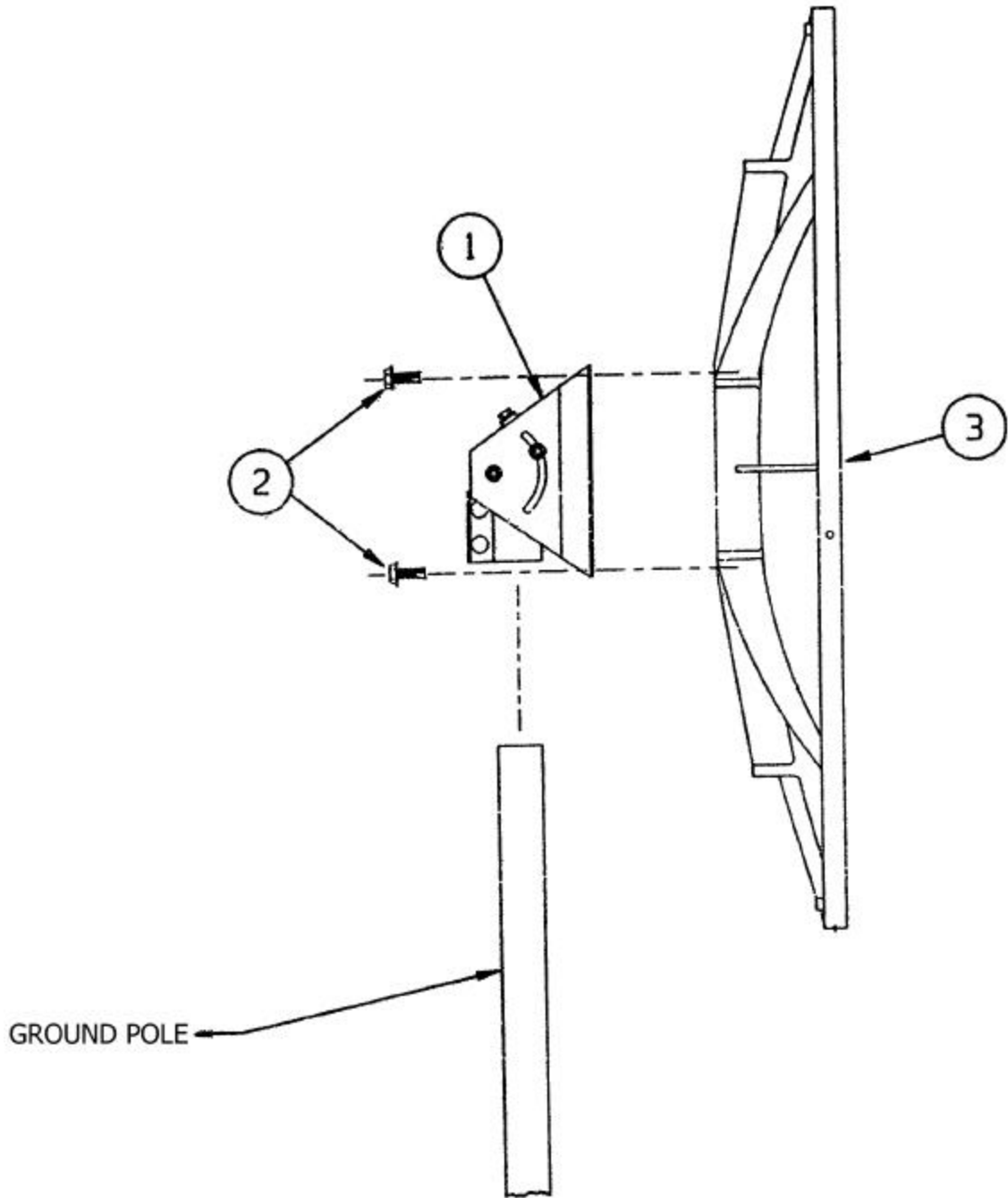

Figure 2.1-1

2.2 Feed Assembly

This section covers the feed assembly for the antenna system Refer to the parts list and figures and follow the instructions in the listed sequence.

- Step 1:** Loosely attach the feed rods (items# 1,2) to the reflector with the hardware shown for your reflector. See Figure 2.2-1. Note that the two long rods attach to the sides of the reflector and the shorter rod attaches to the bottom of the reflector. The bent end of each rod attaches to the reflector.
- Step 2:** Attach the feed mounting bracket (item #13) to the ends of the feed rods with 1/2-20 x .75" bolt, lock washer, and hex nut. (Item #14,6,7) as shown in figure 2.2-2. Tighten all feed support hardware now to 5 ft/lb.
- Step 3:** Assemble the LNB or (OMT and [2] LNB's for dual pole system) to the feed horn.
- Step 4:** Place the feed assembly into the feed mounting bracket and secure by placing the top feed clamp (item #12) over the feed horn and secure with 1/4-20 bolts, lock washers, and hex nuts as shown in figure 2.2-2.
- Step 5:** After final polarization adjustment is made, place spacer (item #9) on lower feedrod bolt and fit cover (item #8) over feed assembly and attach with three [3] 1/4" acorn nuts (item# 10) and spacer (item #9) as shown in figure 2.2-2. Cable should be secured to lower feed rod.

2.2 Feed Assembly Parts List Table

Feed Assembly Parts List Table			
Item No.	Part No.	Description	Qty
1	0176-253	Feed Rod Side .60M	2
	0176-206	Feed Rod Side .76M / C-Band	2
	0176-247	Feed Rod Side .76M / Ku-Band	2
	0176-237	Feed Rod Side .90M	2
	0176-242	Feed Rod Side 1.0M	2
2	0176-254	Feed Rod Bottom .60M	1
	0176-207	Feed Rod Bottom .76M I C-Band	1
	0176-248	Feed Rod Bottom .76M 1 Ku Band	1
	0176-238	Feed Rod Bottom .90M	1
	0176-243	Feed Rod Bottom 1.0M	1
3	Varies	Feed Horn	1
4	8030-008	1/4-20 x 1.00 Bolt (.60/.90 / 1.0M)	3
5	8201-040	1/4" Flat washers (.60/.90 /1.0M)	3
6	8202-040	1/4" Lock washer	5
7	8100-007	1/4-20 Hex Nut	5
8	0338-074	Feed cover	1
9	0159-264	Spacer	1
10	8100-010	1/4" Acorn nut	3
11	8319-004	Hi-Lo Ref. Screw (.76M)	3
12	4080-060	Top Feed Clamp	1
13	4080-059	Feed Mounting Brkt	1
14	8030-006	1/4-20 x .75" Bolt	4
15	8030-013	1/4-20 x 1.50" Bolt	1
16	8100-015	1/4-20 Hex Flange Nut (.90 /1.0M)	3

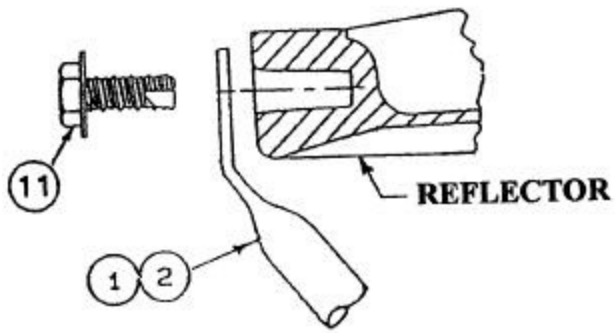

.76M REFLECTOR

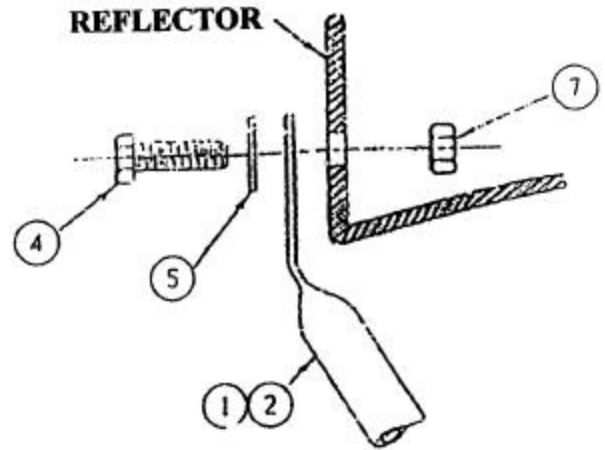

.90 / 1.0M REFLECTOR

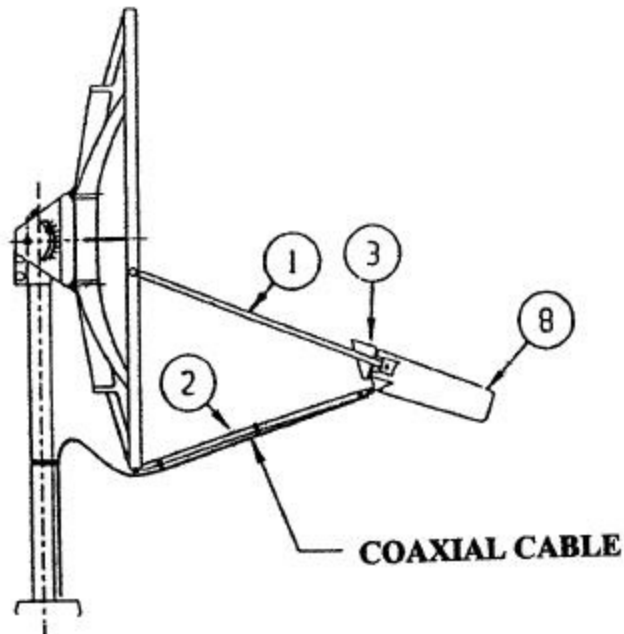

Figure 2.2-1

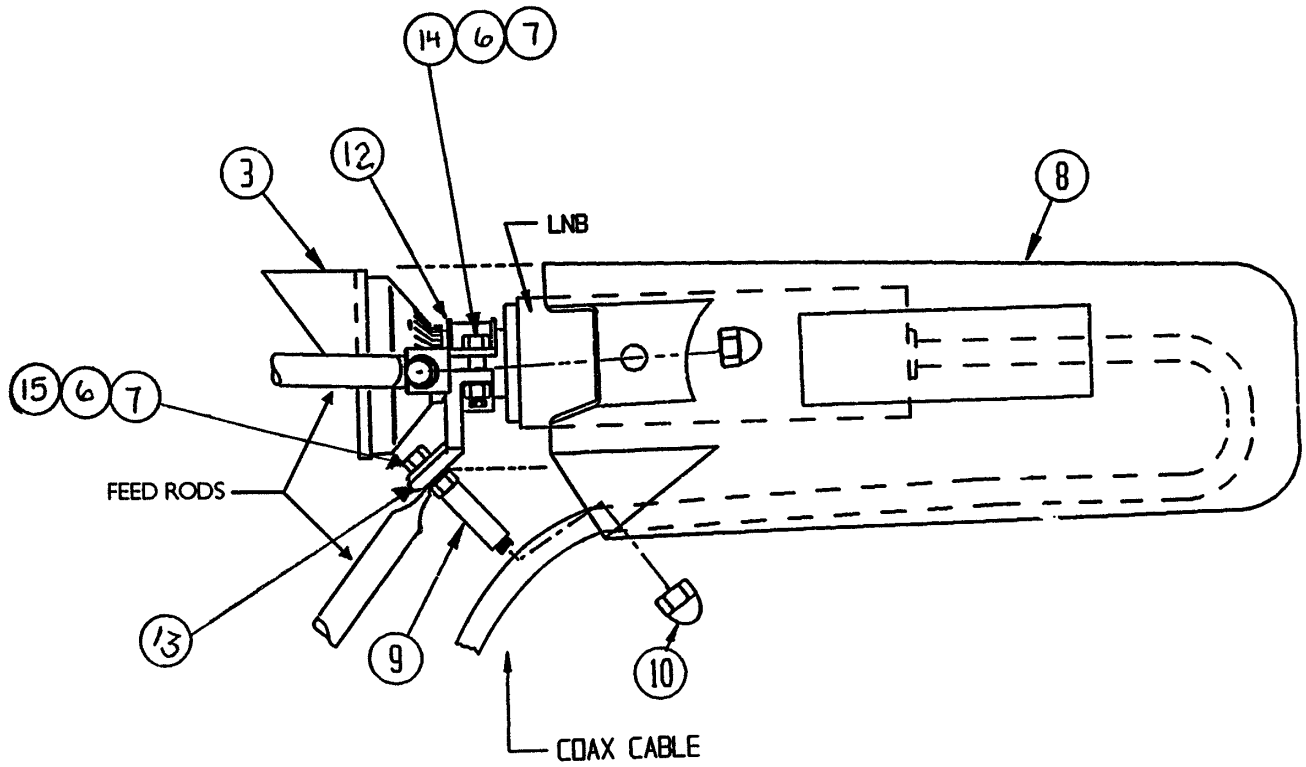

Figure 2.2-2

Section III Satellite Alignment

3.0 *Satellite Alignment*

The antenna assembly is now complete and the antenna is ready to be aligned to the selected satellite.

- Step 1:** To adjust polarization, loosen the two 1/4" bolts on the feed bracket and turn the feed/LNB assembly until the correct polarization setting is aligned with the alignment mark on the feed bracket. See figure 3.0-1. Tighten the two 1/4" bolts to 5 ft/lb.
- Step 2:** Refer to the elevation scale located on the side of the Az/El positioner as shown in figure 3.0-2. To set the antenna system to the correct elevation angle, loosen the elevation pivot hardware (shown in figure 2.1-1) on both sides of the mount just enough to unlock the lock washers. Then turn the elevation adjustment screw. Note: the scale has a 22.5° offset angle built in. Therefore, when the elevation angle is read on the scale, the 22.5° offset in the reflector has been accounted for.
- Step 3:** After making the cable connections to the LNB, rotate the antenna in azimuth to the correct azimuth heading using a compass to determine direction. Sweep the antenna slowly in azimuth until a signal is found. See figure 3.0.3.
- Step 4:** If the desired signal is not found, it may be necessary to alter the elevation angle slightly, and repeat the above procedure.
- Step 5:** Tighten all adjustment hardware on the Az/El Cap to 11 ft/lb.



Figure 3.0-1

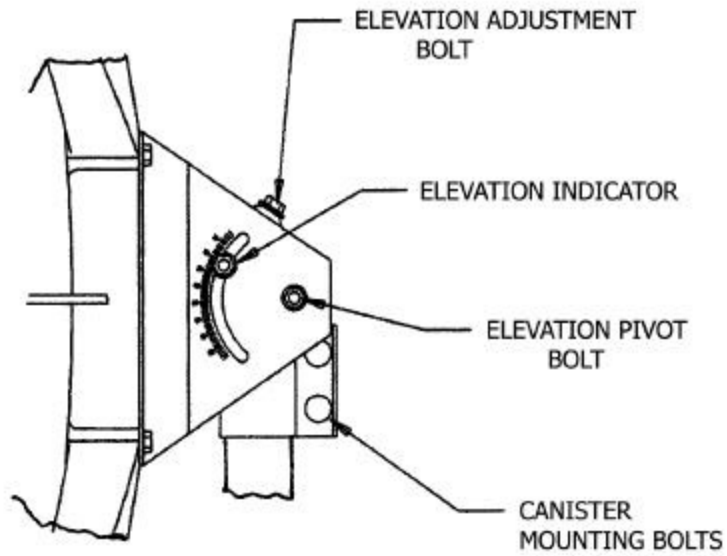

Figure 3.0-2

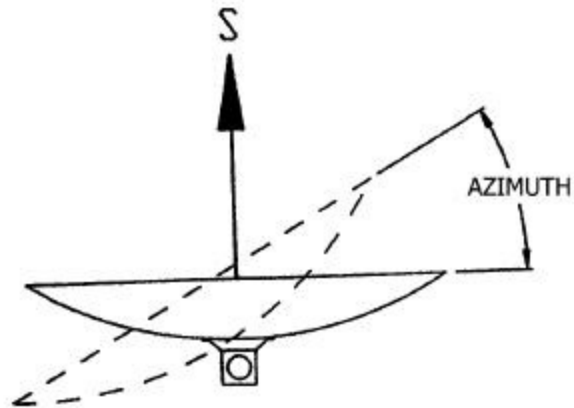

Figure 3.0-3

Section IV Maintenance

4.0 Maintenance Overview

After installation, the antenna requires only periodic inspection. It is anticipated that maintenance, if required, will be minimal and easily handled by a local or in-house maintenance staff. The materials used in the construction of this Earth Station Antenna virtually eliminate any maintenance repairs.

4.1 Periodic Inspection

It is suggested that a periodic inspection be performed at least every six months.

Note: After any severe weather conditions, inspection of the antenna should be performed to determine if foreign objects have caused damage or if survival specifications have been exceeded.

This inspection should include the following:

- Step 1:** **Check all bolting locations** - all bolts should be tight.
- Step 2:** **Check all structural members** - repair or replace if damaged.
- Step 3:** **Check the foundation anchor bolts** - they must be secure and no failure signs in foundation.
- Step 4:** **Check for corrosion** - on the reflector structure and the mount.